

The A-Class Saloon



Mercedes-Benz





The saloon. Now also as an A-Class.

It's the way we used to draw cars when we were children: divided up into engine compartment, interior and luggage compartment. According to the so-called 3-box design. And the new A-Class gets us dreaming along these lines again. The profile is so dynamic yet timelessly elegant. The new A-Class Saloon with MBUX (Mercedes-Benz User Experience) and sporty 3-box design.



More spacious feeling.



Knows the way home. And your habits.

MBUX, the new Mercedes-Benz User Experience, introduces artificial intelligence into the new A-Class. It learns more every day and most of all gets to know its driver more and more. It can remember your favourite songs and the way to work. It then automatically sets the right radio station or shows you a faster way if your usual route is congested. All by itself and as a matter of course, if that is what you want.



Energising comfort and exemplary safety.

In the rush hour, during a long drive at night or on an unfamiliar route – your A-Class noticeably takes the strain out of driving, particularly in stressful situations. It's all down to a concept that makes every journey in a Mercedes-Benz a safer and exceptional experience: Mercedes-Benz Intelligent Drive, an optional feature. Because the time you spend behind the wheel is your time. Time for relaxation. Time to replenish your energy. So that you reach your destination first and foremost more safely, and also arrive more relaxed.



The rear of the A-Class Saloon.
The dawn of a new design era.



The new and puristic styling of the A-Class finds elegant fulfilment in the Saloon: it features a distinctive rear end, in which two-piece tail lamps add to the impression of breadth. The load compartment is not just nice, but also very ample. Additionally, the HANDS-FREE ACCESS function allows you to open and close it with a simple foot gesture.

The new A-Class Saloon.





Mercedes-Benz User Experience.

MBUX (Mercedes-Benz User Experience) does not drive for you, but it makes it as pleasant as possible for you. Thanks to artificial intelligence the system can learn to adapt more and more to drivers over time. With the intelligent LINGUATRONIC voice control system you can almost speak as naturally as you would to a close friend.



Smartphone Integration.

In the new A-Class Saloon you can charge your smartphone by placing it in the centre console. And the best thing: thanks to near-field communication (NFC), your smartphone immediately connects to the A-Class Saloon without lots of intermediate steps or having to enter a code.

Sending text messages or scrolling through contacts is also no problem at all. In the new A-Class Saloon you can use your smartphone without having to pick it up. Use USB or NFC to connect it to the vehicle. Then conveniently control almost all apps and functions via the multimedia system display using the Touch Control buttons on the steering wheel.



Safety and assistance.

The optional radar sensors and 3D stereo camera on the new A-Class Saloon monitors its surroundings and is able to maintain the correct distance to the vehicle ahead at up to speeds of 210 km/h as well as brake automatically in an emergency situation.



MULTIBEAM LED.

The optional MULTIBEAM LED headlamps adapt to visibility and other road users within a split second. For instance the partial main beam does not affect identified road users so the road surface is always ideally illuminated without dazzling oncoming vehicles.



“Wrap-around” design.

The interior of the new A-Class Saloon literally hugs occupants. Smooth transitions between instrument panel, centre console and door trims create the pleasant wrap-around design. This is just as special in this category as the selection of trim elements and ambient lighting to showcase every detail perfectly.

Widescreen display.

Here one glance says more than a thousand words. The interior of the new A-Class Saloon impresses by extraordinary looks to give you completely new perspectives. Including two 10.25” (26 centimetres) high resolution displays, 1 all-digital instrument display as standard and another central media display. In any case, the screens seem to be floating within the interior. They are also super easy to operate using the Touch Control buttons on the steering wheel. The latter represents an additional world-first that is definitely worth another look.



Head-up display.

You will automatically have your eyes on the road with the head-up display, available as an option in the new A-Class Saloon because it directly projects all relevant information, such as speed, speed limits or navigation information into your field of vision. Virtually and in full colour. Adapt the contents of the display field and save your preferences using the memory function.



Seating comfort and spaciousness.

If you take a look around in the new A-Class Saloon, you may be surprised to find just how spacious it is. In particular the rear will also provide sufficient legroom for taller persons. The new A-Class features sports seats with adjustable head restraints. Multicontour seats are available as an option in conjunction with luxury seats. Seat climate control and additional upholstery is available. For travelling comfort at a luxury level.

The Progressive design and equipment line.

The Progressive design and equipment line substantially enhances your car. Added value you can see and feel. The allure and high-end technical features of a compact premium saloon are highlighted from every perspective.



The AMG Line.

With the AMG Line you are making a clear statement on performance both inside and out. Above all, the AMG bodystyling with special front and rear aprons lends the car a resemblance to AMG models. In addition, the technical features with lowered, sportily tuned suspension and the Direct-Steer system serve to intensify the driving experience.

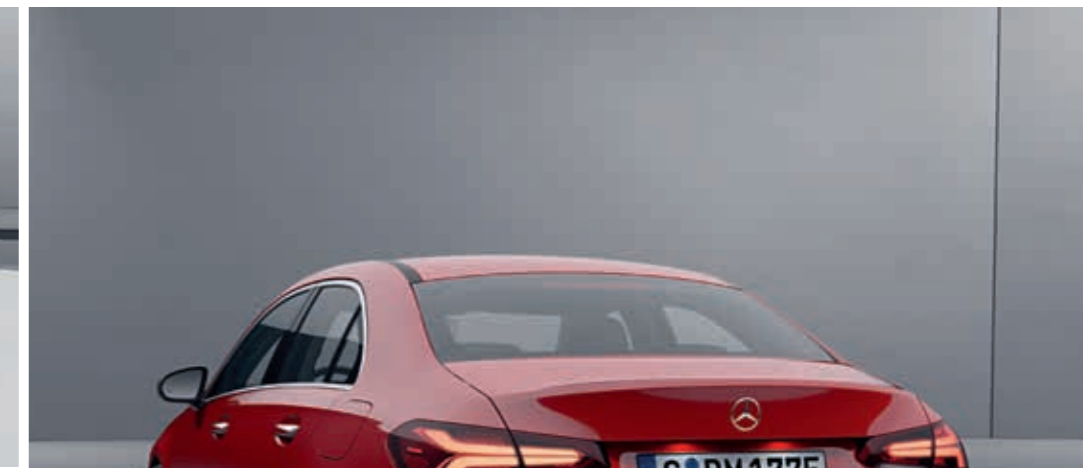



DYNAMIC SELECT.

Just drive as you want to. At the press of a button DYNAMIC SELECT offers different drive programs with setting options for the engine, transmission, chassis and steering, for instance. In "Sport" mode the vehicle is more dynamic and in basic "Comfort" mode its setup is very well balanced. "ECO", on the other hand, places the emphasis on maximum efficiency, saving both fuel and money.

The "ECO" drive program gives you particularly comprehensive support when you want to avoid CO₂ and pollutants. The seat heating and air conditioning work with reduced output in this setting and thus also save valuable energy. In "Individual" you choose all the respective parameters yourself. This means that you can select a sporty setting for the drive system and at the same time have a comfortable setting for the chassis.



Comfort suspension.

Enjoy a high level of comfort on long motorway stretches while tackling tight curves with sporty flair. The well balanced comfort suspension provides an impressive mix of responsive

suspension reserves and excellent driving stability. This makes your driving safe while at the same time providing a great deal of driving pleasure.

Instant performance.

Every Mercedes-AMG is a masterpiece in its own right, with an unmistakable character. What unites our performance vehicles and sports cars is their irrepressible sporting spirit. Their passion for top performance. It is generated at the point where engineering skill meets a very special attitude: the spirit of AMG. We believe that you have to keep on challenging limits in order to achieve new goals. We accept nothing as a given. Because limits are imposed by people, and it's also people who can overcome them. It's this attitude that enables us to achieve outstanding performance for the race track – and for the road.

Welcome to the world of AMG.

www.mercedes-amg.com

AMG
DRIVING PERFORMANCE



Technical data.

	Petrol engines		
	A 200 Progressive	A 200 AMG Line	A 250 AMG Line
No. of cylinders/arrangement	4/In-line	4/In-line	4/In-line
Displacement (cc)	1,332	1,332	1,991
Rated output (hp/rpm)	163/5500	163/5500	224/5500
Rated torque (Nm/rpm)	250/1620-4000	250/1620-4000	350/1800-4000
Acceleration from 0 to 100 km/h (s)	8.1	8.1	6.3
Top speed (km/h)	230	230	250
Fuel consumption (l/100km)	5.5	5.5	6.4
VES (Band)	B	B	B

Dimensions.

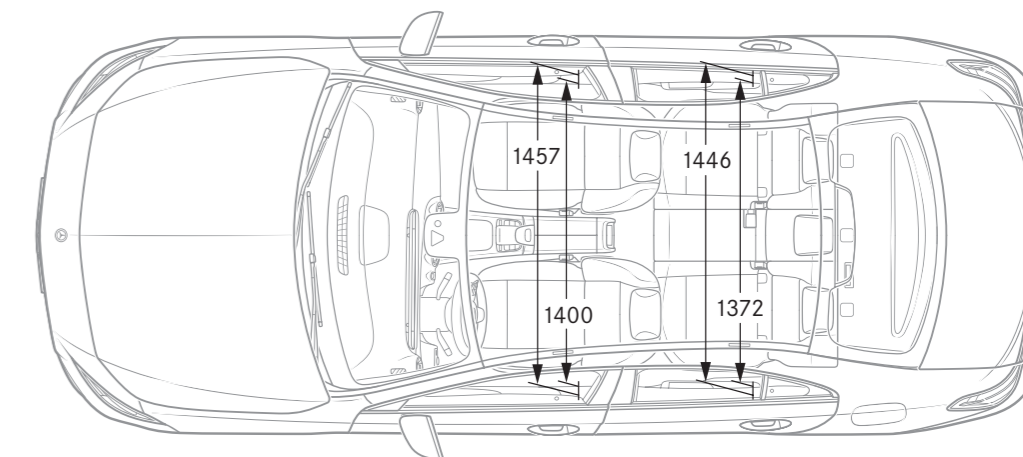
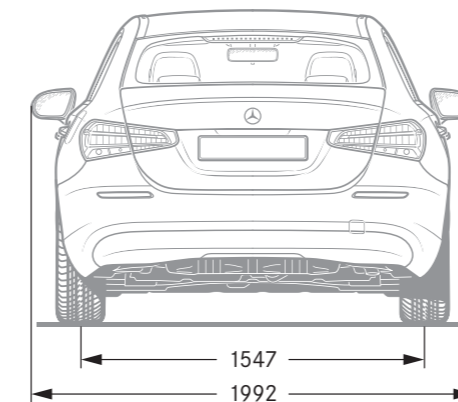
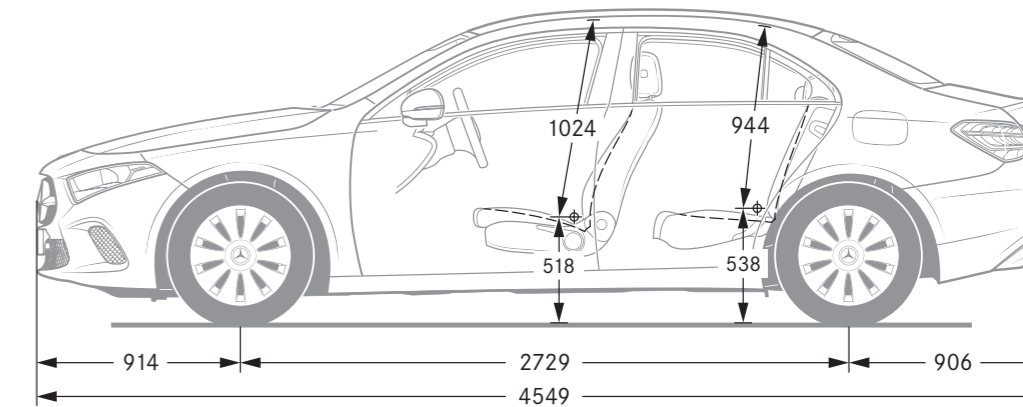
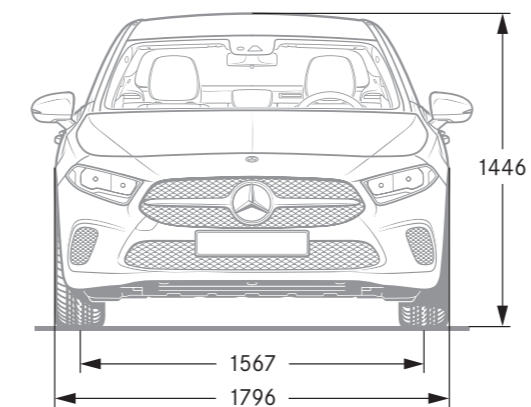

The best for the engine:
Mercedes-Benz genuine engine oils.

¹Rated output and torque figures in accordance with Directive 80/1269/EEC in the currently applicable version. ²Fuel consumption are derived from combined tests & tested by local regulations in accordance with UN ECE R101. Under real-life driving conditions deviations may occur in comparison to the certified standard values. The actual values are influenced by a number of individual factors, such as personal driving style, environmental and route conditions. Further technical data may be found on www.mercedes-benz.com.

All figures in millimetres. The illustrated dimensions are mean values. They are valid for vehicles in basic specification and in unladen condition.



SPORT — F O R — GOOD

Mercedes-Benz is one of the founding partners of the worldwide “Laureus Sport for Good Foundation”, which was established in 2000. It is the Mercedes-Benz brand’s most important social initiative. Laureus Sport for Good supports children and young people in need through social sports projects, opening up new perspectives and imparting important values such as team spirit, respect and determination. “Change the Game for Kids” is our mission statement which we wish to share with you. In buying a Mercedes-Benz you are supporting the “Laureus Sport for Good” movement.

Please note: changes may have been made to the product since the editorial deadline (August 2019). The manufacturer reserves the right to make changes to the design, form, colour and the product specification during the delivery period, provided these changes, while taking into account the interests of the vendor, can be deemed reasonable with respect to the purchaser. Where the seller or the manufacturer uses symbols or numbers to describe an order or the subject of

an order, no rights may be derived solely from these. The illustrations may show accessories and items of optional equipment which are not part of standard specification. For current and more specific information in relation to the regulations and requirements in your own country and their consequences, please contact your nearest authorised Mercedes-Benz Passenger Car Dealer, Cycle & Carriage at 6298 1818. www.mercedes-benz.com.sg.